



## Specifications

### Batten Material

Hardwood Spotted Gum

Enviroslat Composite Woodgrain

### Frame Finish

Mild Steel Galvanised

Mild Steel Powdercoated

Stainless Steel Satin Polished

### Fixing Type

Bolt Down Fixing

Extended Leg (Into Footing)

Sub Surface Bolt Down (Specify Depth)

### Wheelchair Access

One Leg inset 620mm

No End Access

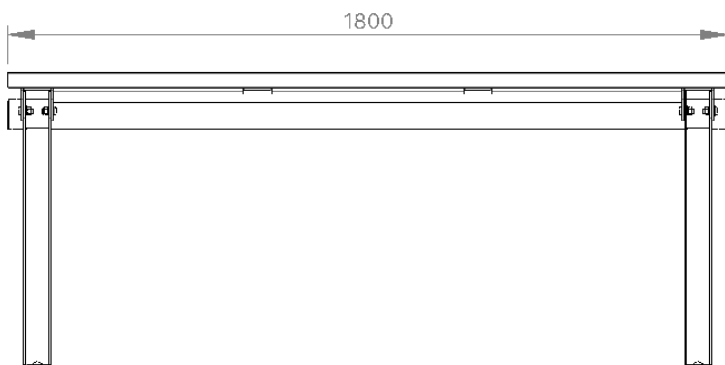

FRONT

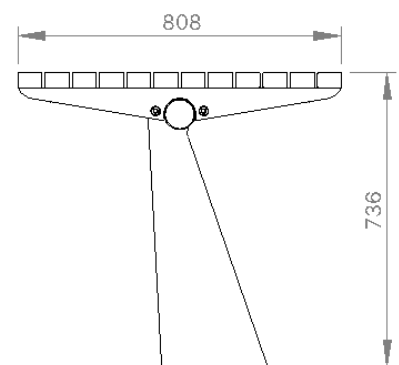

RIGHT