

Specifications

Batten Material

Hardwood Spotted Gum

Enviroslat Composite Woodgrain

Frame Finish

Mild Steel Galvanised

Mild Steel Powdercoated

Stainless Steel Satin Polished

Fixing Method

Bolt Down Fixing

Extended Leg (Into footing)

Sub Surface Bolt Down

Modular

Yes (Used in modules)

No (Standalone)



FRONT

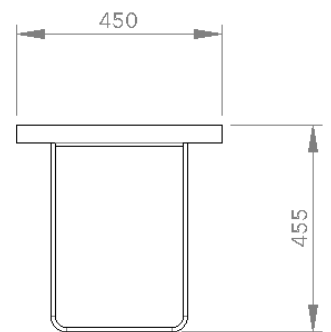

RIGHT