



Specifications

Batten Material

Hardwood Spotted Gum

Enviroslat Composite Woodgrain

Aluminium Aussie Gum

Fixing Type

Bolt Down Fixing

Extended Leg (Into Footing)

Sub Surface Bolt Down (Specify Depth)

Umbrella Plate

With Umbrella Plate

Without Plate

Frame Finish

Mild Steel Powdercoated

Stainless Steel Satin Polished

Weathering Steel Corten

Wheelchair Access

Both legs inset 450mm

No End Access

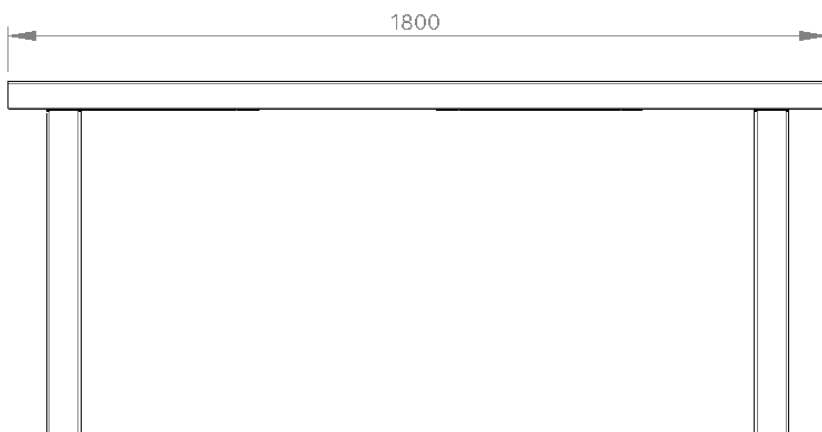

FRONT

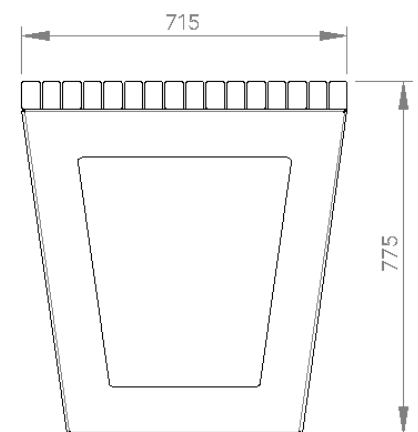

RIGHT