

Specifications

Frame Finish

Mild Steel Galvanised

Stainless Steel Satin Polished

Weathering Steel Corten

Fixing Method

Bolt Down

Cast In Concrete Sub-Frame

Size

1000x1000mm With 350mm ID Hole

1200x1200mm With 450mm ID Hole

1500x1500mm With 500mm ID Hole

Perforation Type

Type A

Type B

Type C

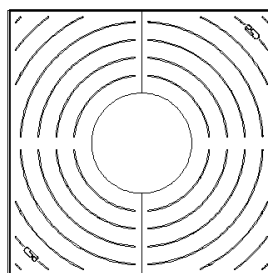
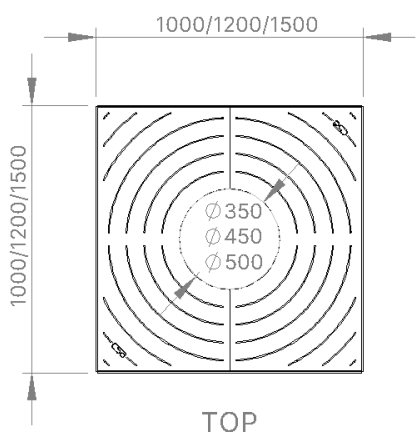

PERFORATION
 TYPE A

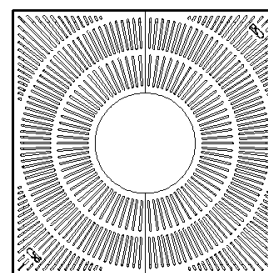

PERFORATION
 TYPE B

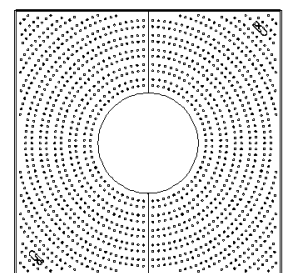

PERFORATION
 TYPE C