



Specifications

Batten Material

Hardwood Spotted Gum

Enviroslat Composite Woodgrain

Frame Finish

Mild Steel Galvanised

Mild Steel Powdercoated

Stainless Steel Satin Polished

Fixing Type

Bolt Down Fixing

Extended Leg (Into Footing)

Sub Surface Bolt Down (Specify Depth)

Wheelchair Access

Both Legs Inset 450mm

One Leg inset 620mm

No End Access

Umbrella Plate

With Umbrella Hole (47mm)

Without Umbrella Hole

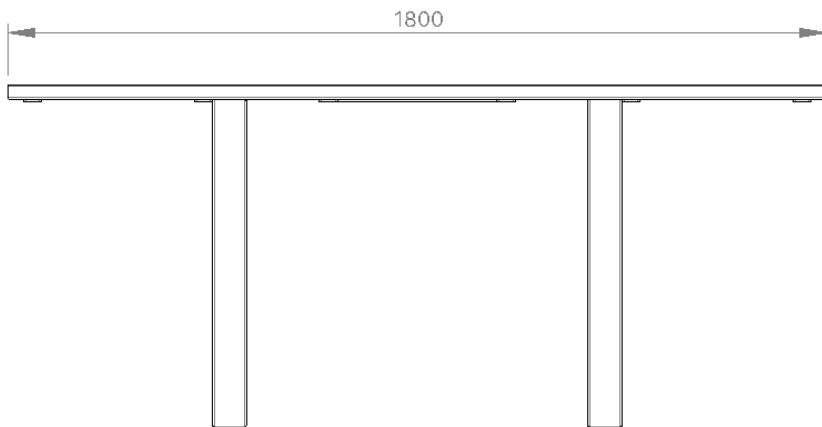

FRONT

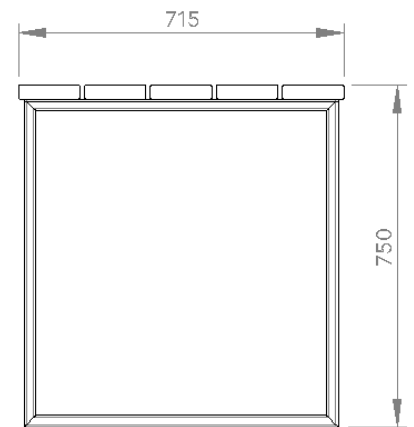

RIGHT