

INSTALLATION DETAILS (Recommendations only)

Concrete footings, 25mPa:

- Two 600x300x300mm minimum footing size
- Bolt down to footings with 4x M12x75mm Dynabolts or similar
- For spigot fixed option, set product(s) into footings

or

Concrete slab, 25mPa:

- One 1900x600x100mm (minimum) thick slab recommended

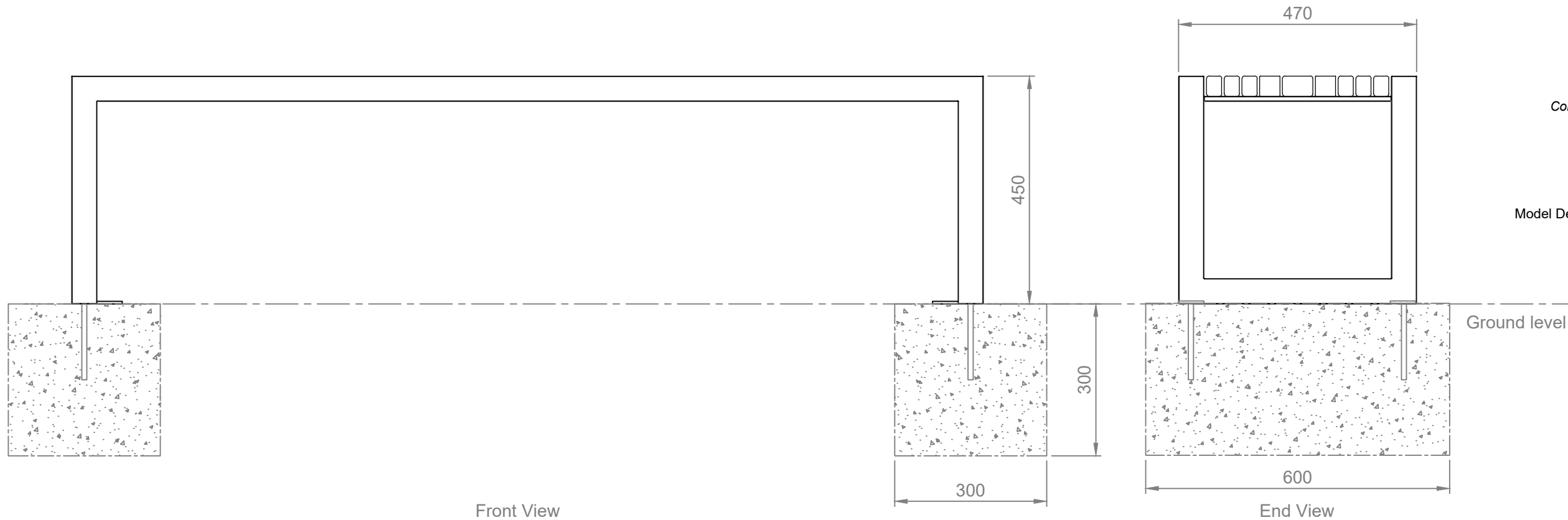
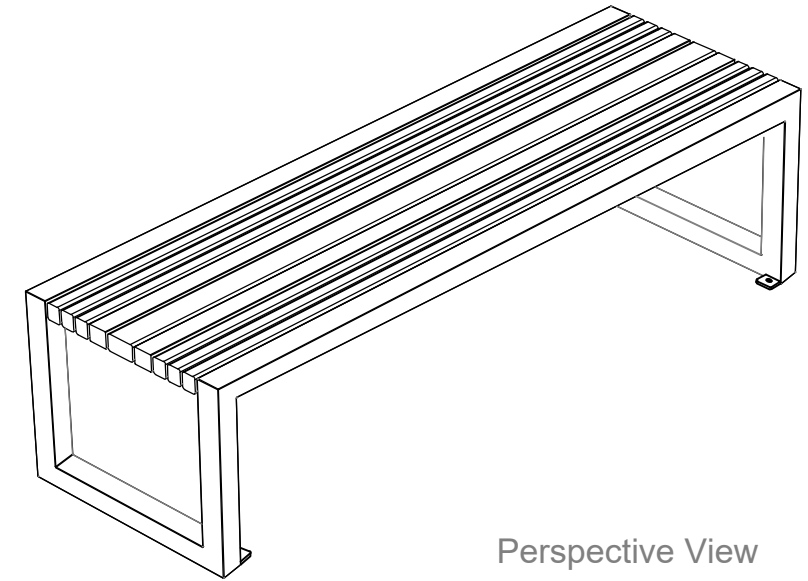
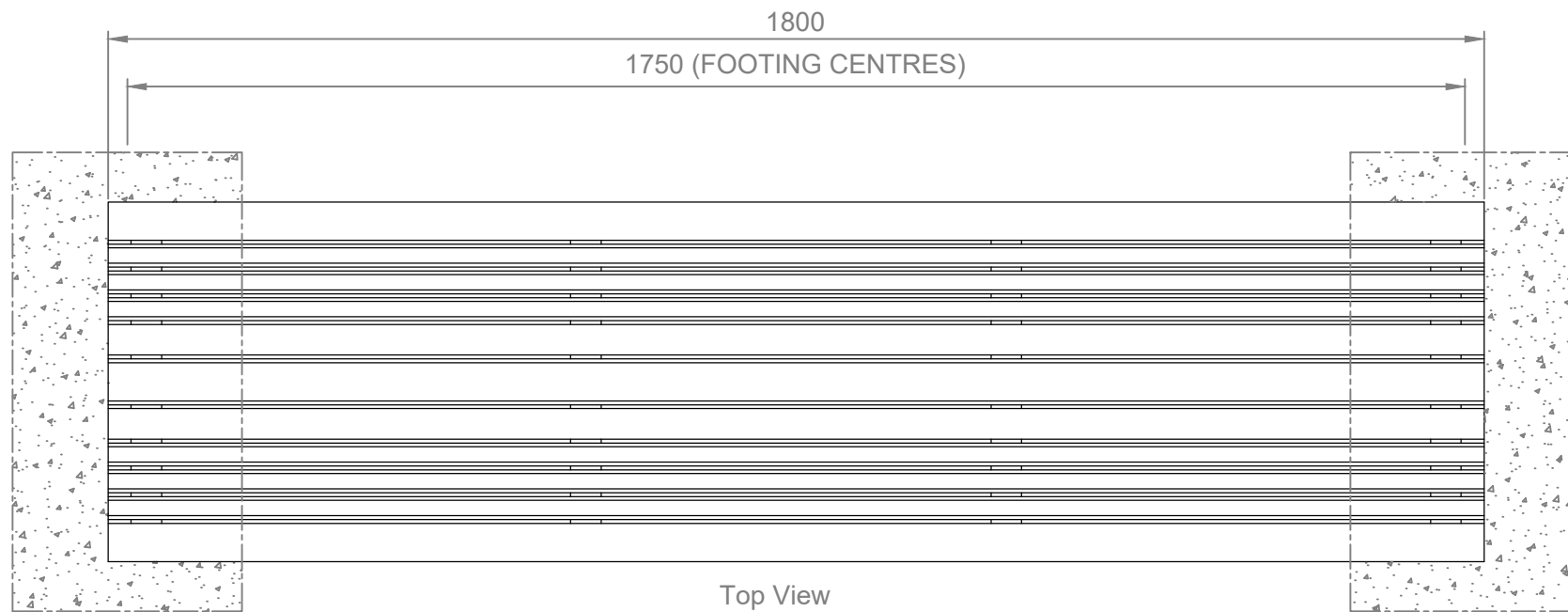

Commercial Systems Australia Pty. Ltd.

42 Orchard St, Kilsyth South, VIC
 phone: (03) 9723 4111
 fax: (03) 9723 3494
 email: design@commercialsystems.com.au

Model Code: TM4562
 Model Description: Quadro Bench 1800mm

Drawing: CS1121

Sheet Number: -
 Sheet Description: Installation

Drawn By: J.Stuckings
 Date Drawn: 31.05.2013
 Revision Number: 4

SCALE 1:1

ALL DIMENSIONS IN MILLIMETERS
 UNLESS OTHERWISE STATED
 ALL PARTS CENTRED UNLESS SPECIFIED

TOLERANCES	
X	+/- 1mm
X.X	+/- 0.5mm
X.XX	+/- 0.05mm