

INSTALLATION DETAILS (RECOMMENDATIONS ONLY)

CONCRETE FOOTINGS, 25MPA:

- ONE 800X500X300MM MINIMUM FOOTING SIZE - BOLT DOWN TO FOOTINGS WITH 4X M12X75MM DYNABOLTS OR SIMILAR

CONCRETE SLAB, 25MPA:

- ONE 150mm (MINIMUM) THICK SLAB RECOMMENDED

- 1 - FIX BASE FRAME TO FOOTING OR SLAB WITH DYNABOLT OR SIMILAR (NOT SUPPLIED)
PACK UNDERNEATH TO LEVEL BASE AS REQUIRED.
- 2 - FIX BENCH TO BASE FRAME WITH SUPPLIED M12 FIXINGS

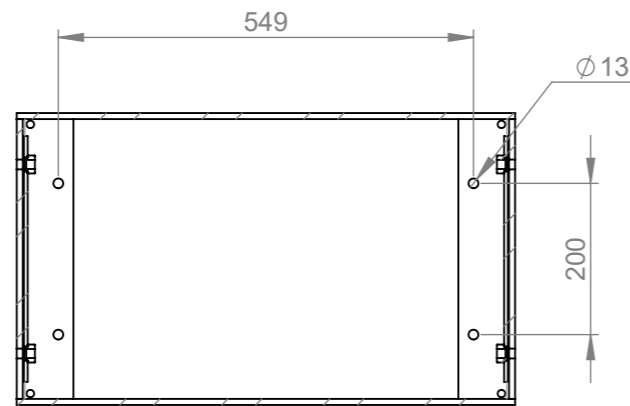

SECTION D-D

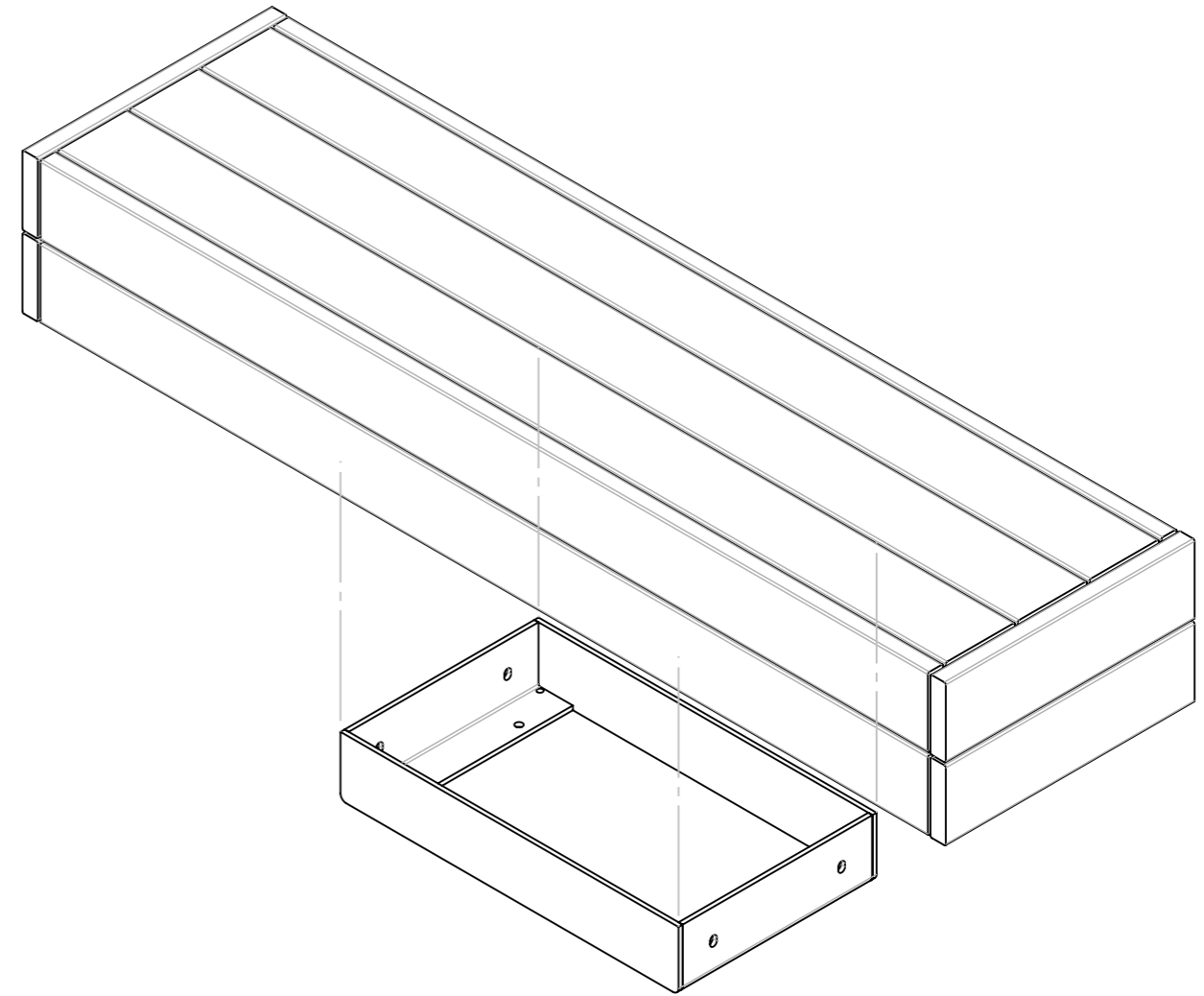

ISOMETRIC VIEW



FRONT VIEW

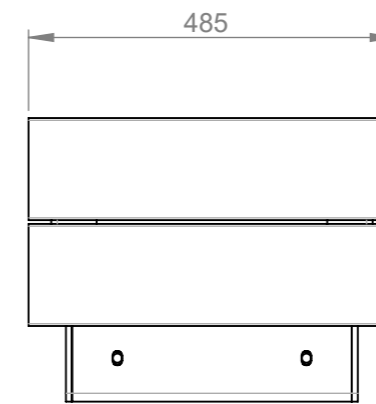

END VIEW



Commercial Systems Australia Pty. Ltd.

42 Orchard Street, Kilsyth South, VIC
phone: (03) 9723 4111
fax: (03) 9723 3494
email: design@commercialsystems.com.au

Model Code: TM4530
Model Description: Wharf Bench. 135x30mm

Drawing: CS7510

Sheet Number: 9
Sheet Description: Install

Drawn By: GS
Date Drawn: 9/08/2021

Revision Number: 0

Revision Details:

SCALE 1:10

ALL DIMENSIONS IN MILLIMETERS
UNLESS OTHERWISE STATED
ALL PARTS CENTRED UNLESS SPECIFIED

TOLERANCES

X	+/- 1mm
X.X	+/- 0.5mm
X.XX	+/- 0.05mm