

**INSTALLATION DETAILS (Recommendations only)**

**Concrete footings, 25mPa:**

- Two 500x300x300mm minimum footing size
  - Bolt down to footings with 4x M12x75mm Dynabolts or similar
  - For extended leg option, set product(s) into footings
- or

**Concrete slab, 25mPa:**

- One 1900x550x100mm (minimum) thick slab recommended

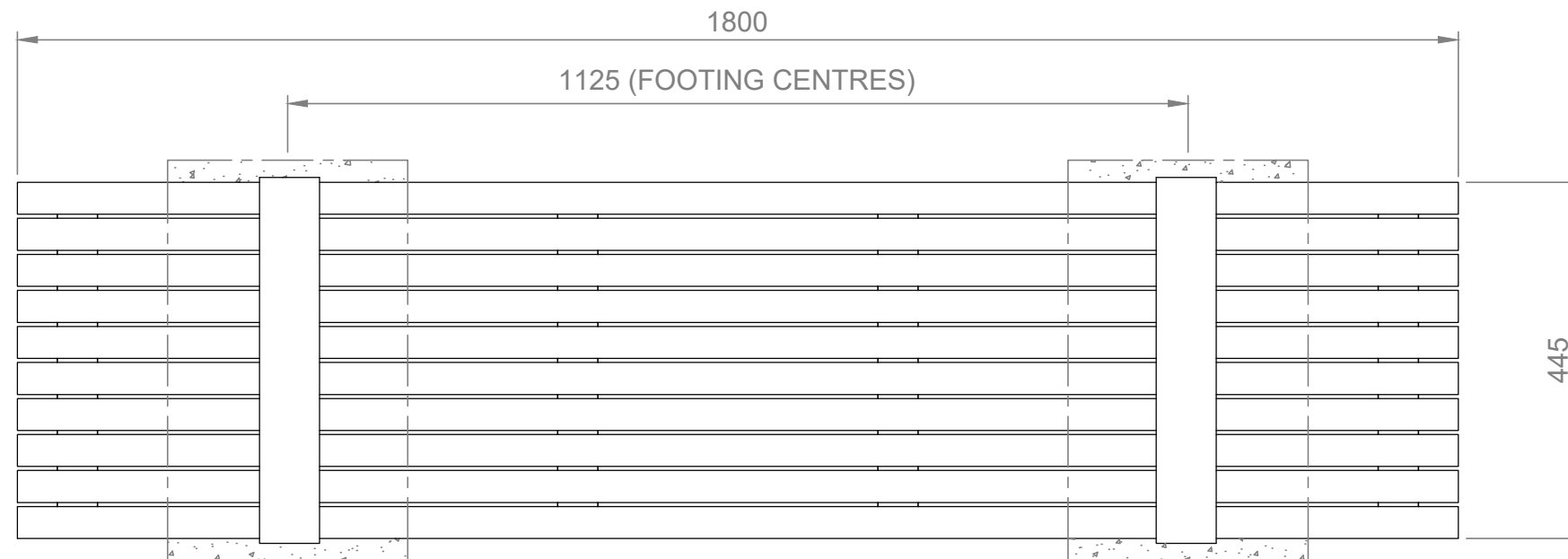

Top View

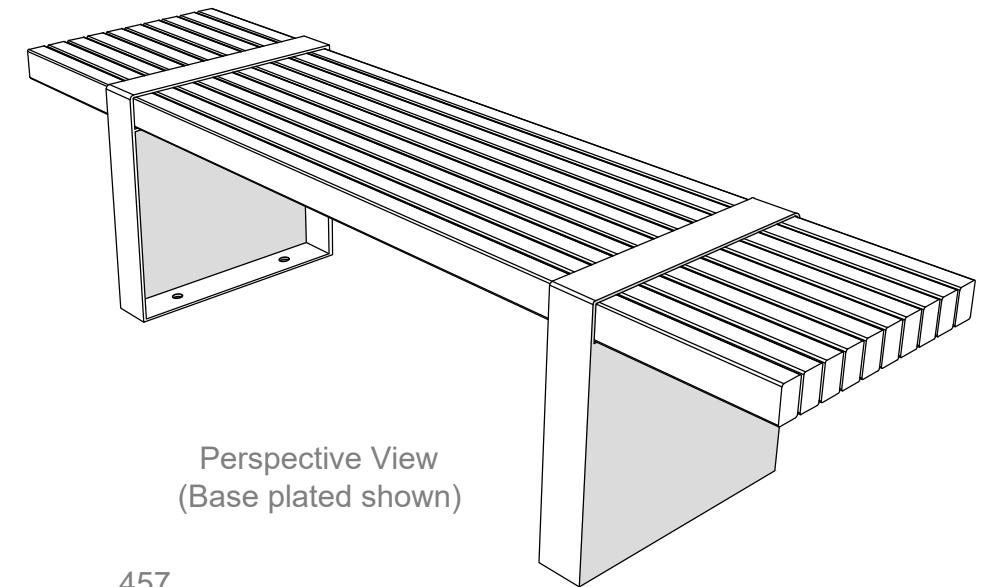

Perspective View  
(Base plated shown)

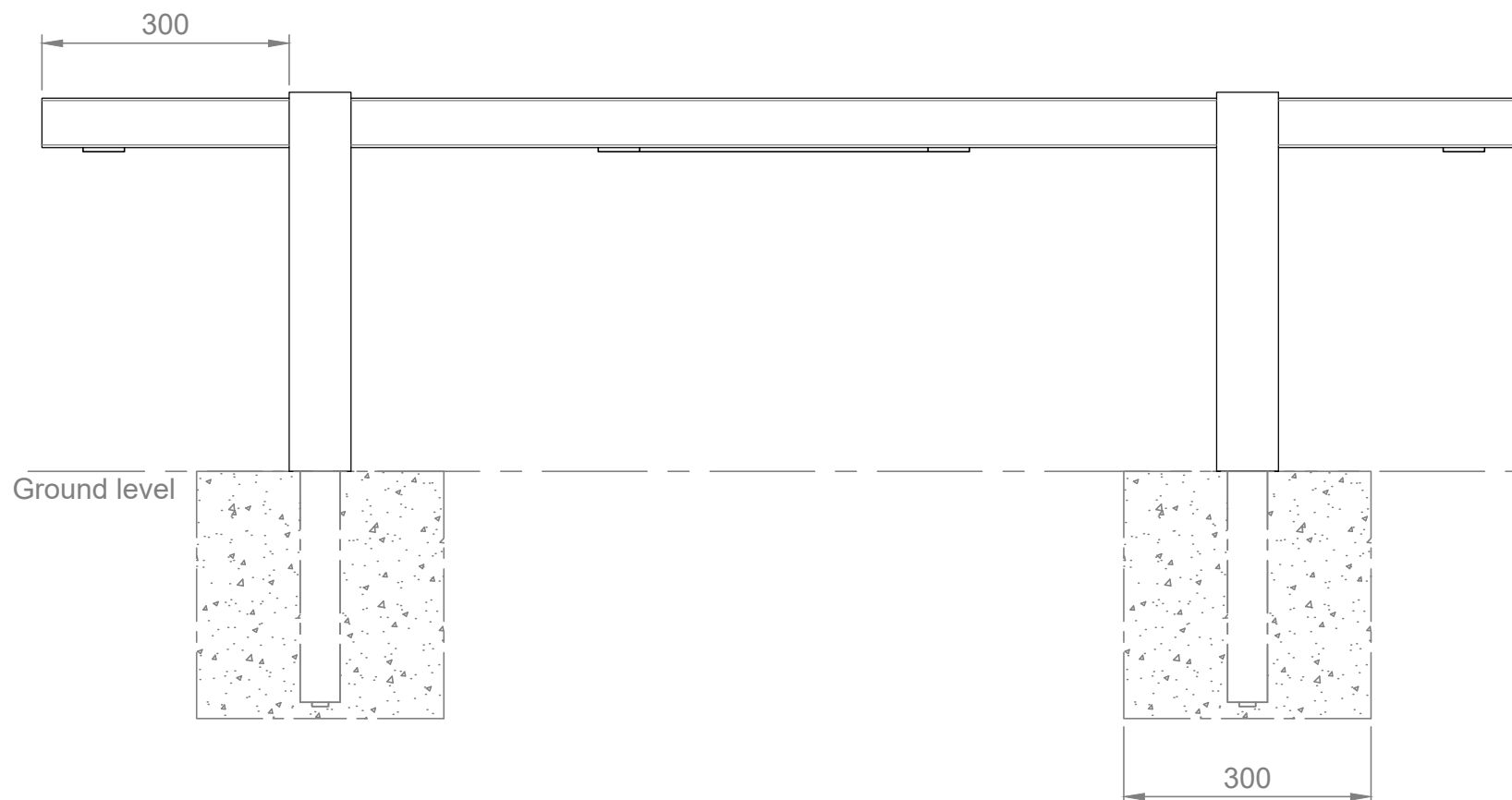

Front View

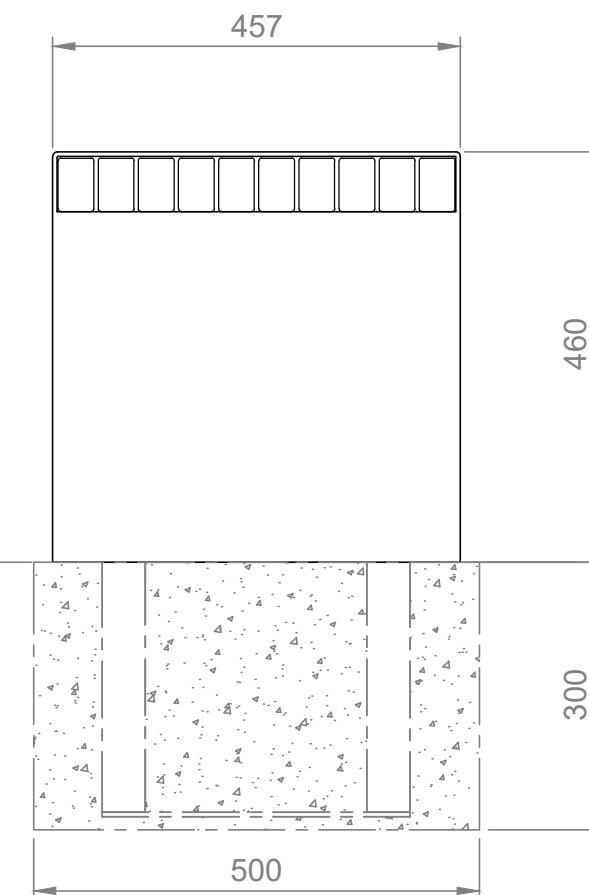

End View



Commercial Systems *Australia Pty. Ltd.*

42 Orchard Street, Kilsyth South, VIC  
phone: (03) 9723 4111  
fax: (03) 9723 3494  
email: design@commercialsystems.com.au

Model Code: TM4503  
Model Description: Urbania Bench without arms

**Drawing: CS0704**

Sheet Number: -  
Sheet Description: Installation

Drawn By: G.Smith  
Date Drawn: 12.11.2013  
Revision Number: 5

SCALE 1:1

ALL DIMENSIONS IN MILLIMETERS  
UNLESS OTHERWISE STATED  
ALL PARTS CENTRED UNLESS SPECIFIED

TOLERANCES

|      |            |
|------|------------|
| X    | +/- 1mm    |
| X.X  | +/- 0.5mm  |
| X.XX | +/- 0.05mm |