

Top View

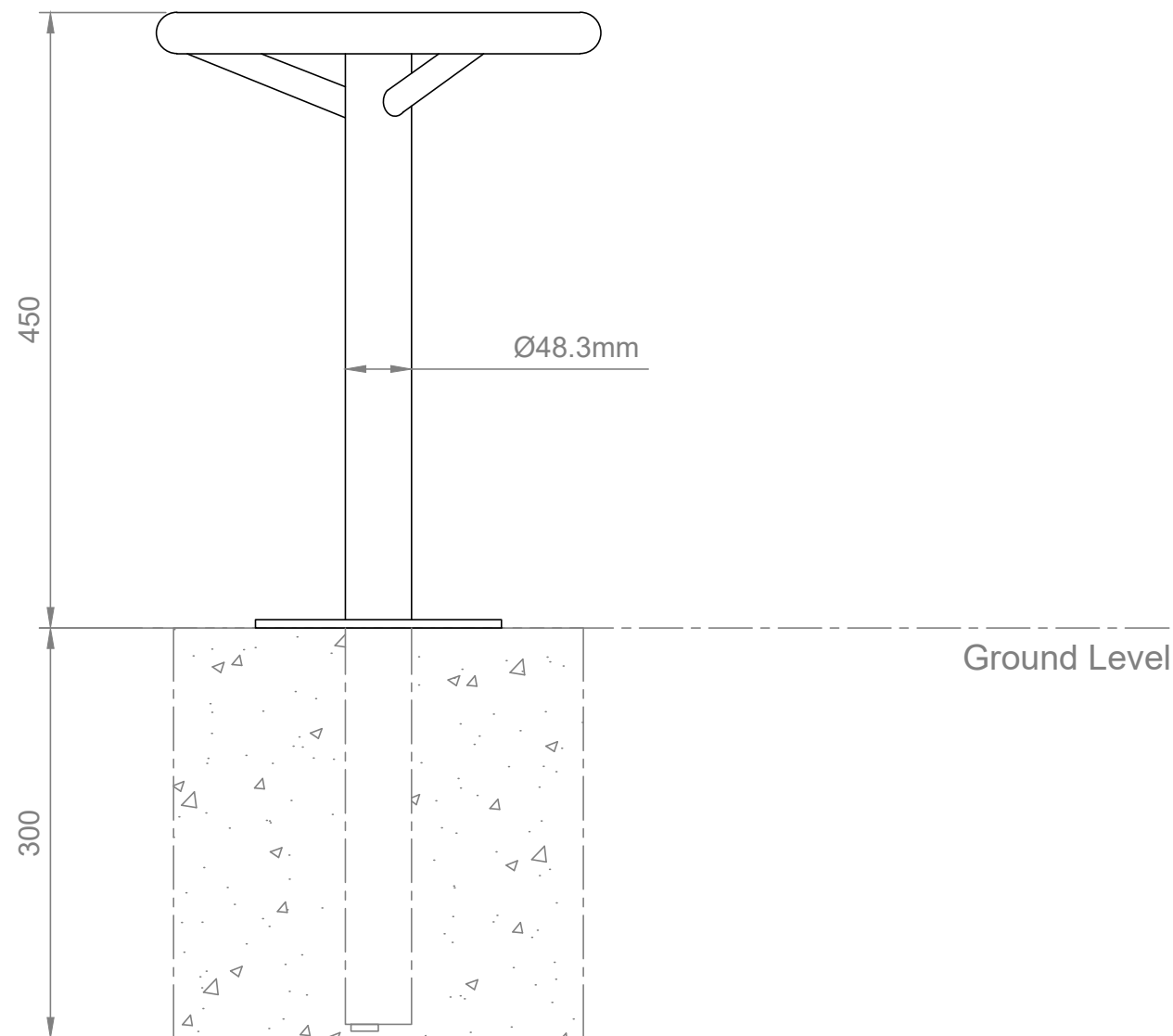

Front View

INSTALLATION DETAILS (Recommendations only)

Concrete footings, 25mPa:

- One 300x300x300mm minimum footing size
 - Bolt down to footings with 3x M12x75mm Dynabolts or similar
 - For extended leg option, set product(s) into footings
- or

Concrete slab, 25mPa:

- One 500x500x100mm (minimum) thick slab recommended



Commercial Systems Australia Pty. Ltd.

42 Orchard St, Kilsyth South, VIC
 phone: (03) 9723 4111
 fax: (03) 9723 3494
 email: design@commercialsystems.com.au

Model Code: PM2053
 Model Description: Market Stool

Drawing: CS0456

Sheet Number: -
 Sheet Description: Installation

Drawn By: C.Artemiou
 Date Drawn: 16.01.2014
 Revision number: 4

SCALE 1:1

ALL DIMENSIONS IN MILLIMETERS
 UNLESS OTHERWISE STATED
 ALL PARTS CENTRED UNLESS SPECIFIED

TOLERANCES

X	+/- 1mm
X.X	+/- 0.5mm
X.XX	+/- 0.05mm