

INSTALLATION DETAILS (RECOMMENDATIONS ONLY)

CONCRETE FOOTING, 25MPA:

- 2 QTY AT 300 X 300 X 300mm MINIMUM FOOTING SIZE
 - BOLT DOWN TO FOOTINGS WITH 8X M12X75MM DYNABOLTS OR SIMILAR
 - FOR EXTENDED LEG SET LEG INTO FOOTINGS
- OR
- CONCRETE SLAB MIN 100mm THICK (STATION DRAWINGS SUPERCEDE MIN REQUIREMENTS)
 - BOLT DOWN TO FOOTINGS WITH 8X M12X75MM DYNABOLTS OR SIMILAR

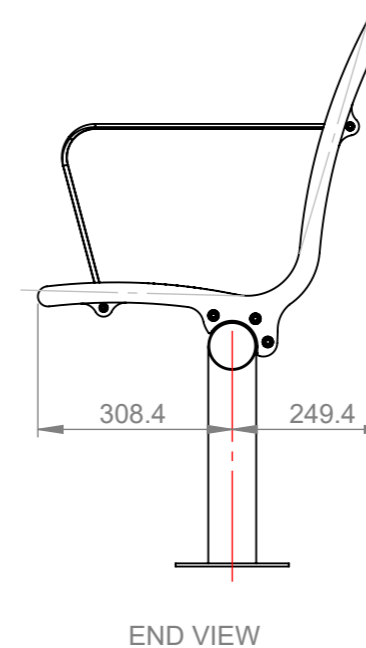
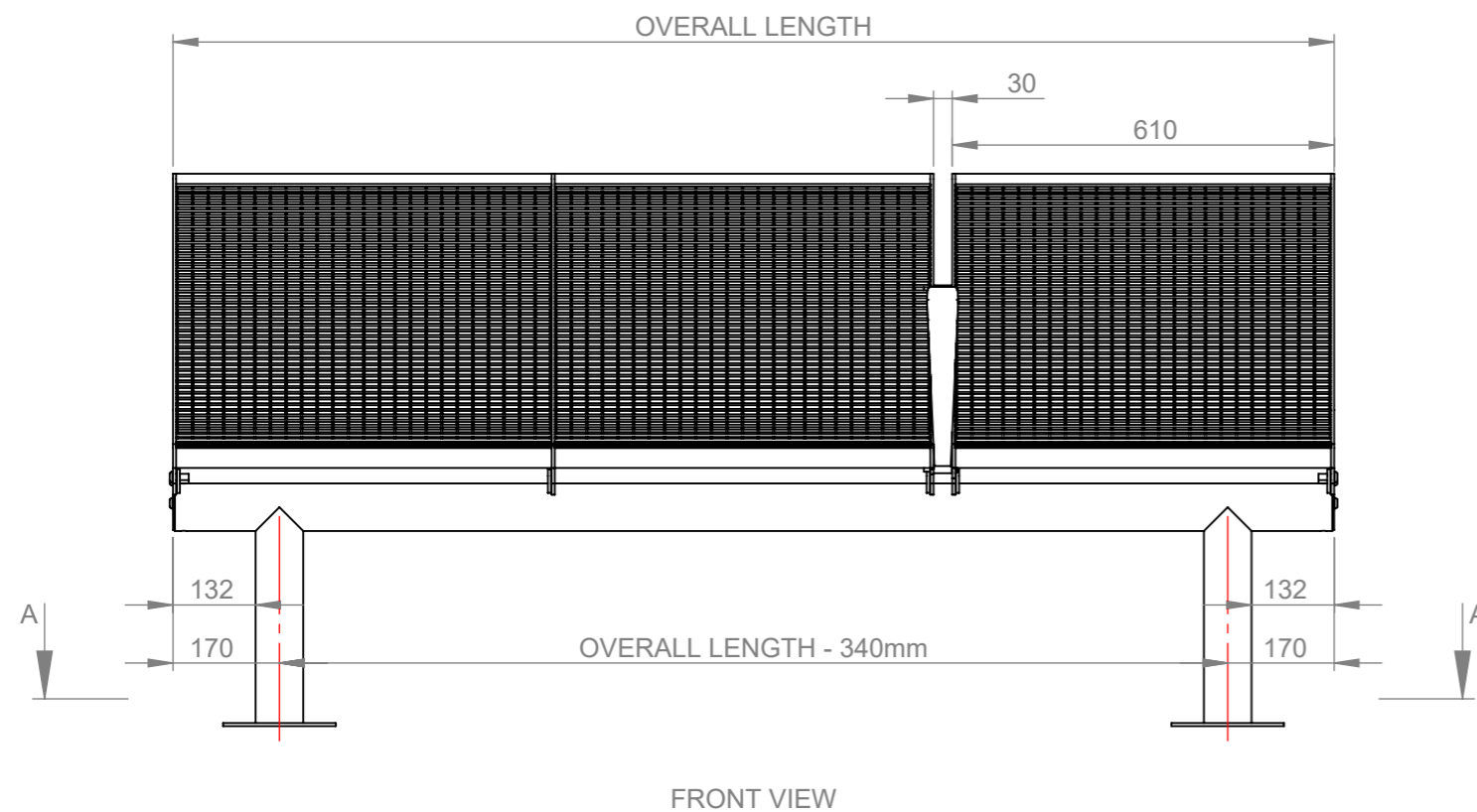
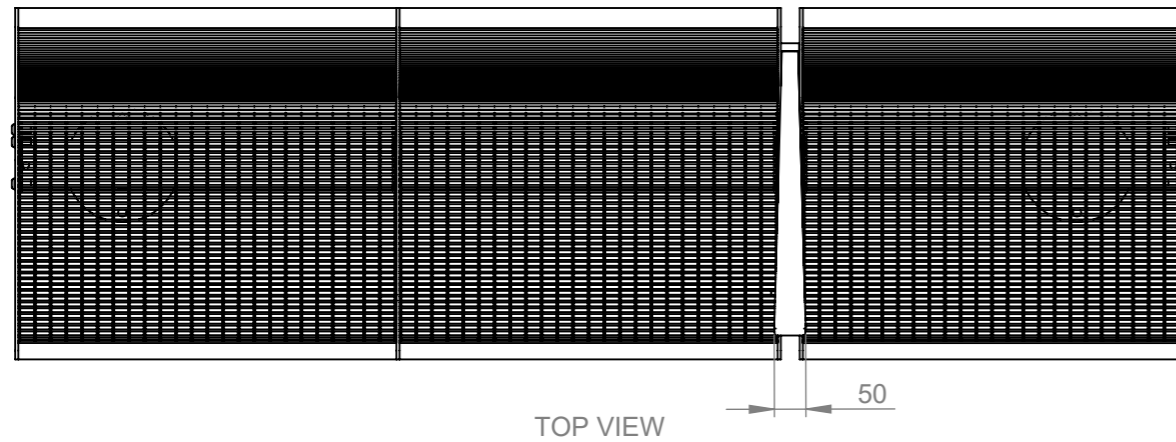
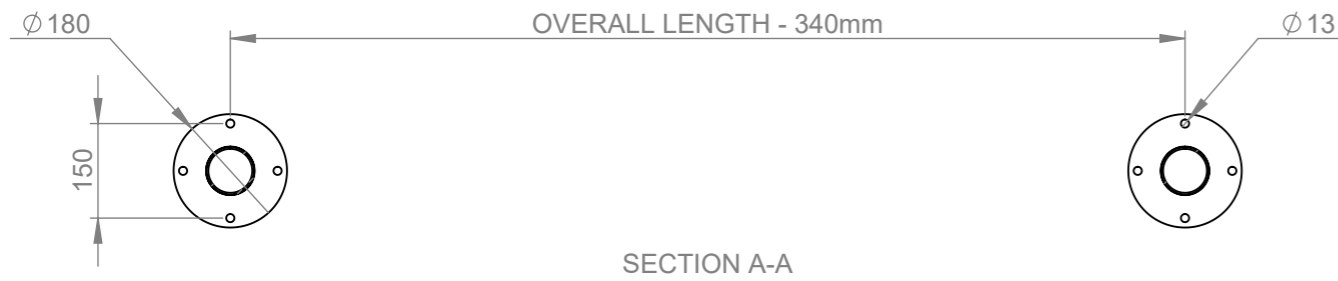

Commercial Systems Australia Pty. Ltd.

42 Orchard Street, Kilsyth South, VIC
phone: (03) 9723 4111
fax: (03) 9723 3494
email: design@commercialsystems.com.au

Model Code: HM3065-
Model Description: Metro Seat

Sheet Description: Install

Drawn By: GS
Date Drawn: 29/06/2018

Revision Number: -
Revision Details:
SCALE 1:12

ALL DIMENSIONS IN MILLIMETERS
UNLESS OTHERWISE STATED
ALL PARTS CENTRED UNLESS SPECIFIED

TOLERANCES

X	+/- 1mm
X.X	+/- 0.5mm
X.XX	+/- 0.05mm